

PROPRIETARY AND CONFIDENTIAL

THE INFORMATION CONTAINED IN THIS DRAWING IS THE SOLE PROPERTY OF DYTRAN INSTRUMENTS INC. ANY REPRODUCTION IN PART OR AS A WHOLE WITHOUT THE WRITTEN PERMISSION OF DYTRAN INSTRUMENTS INC IS PROHIBITED.

DWG NO 127-6717 SH 1 REV 1

REVISIONS

REV.	ECN	DESCRIPTION	BY/DATE	CHK	APPR
------	-----	-------------	---------	-----	------

2 CLEARANCE HOLES FOR #8 OR M4 SCREW

4-40 TAPPED HOLES FOR MOUNTING 7500A SERIES ACCELEROMETERS

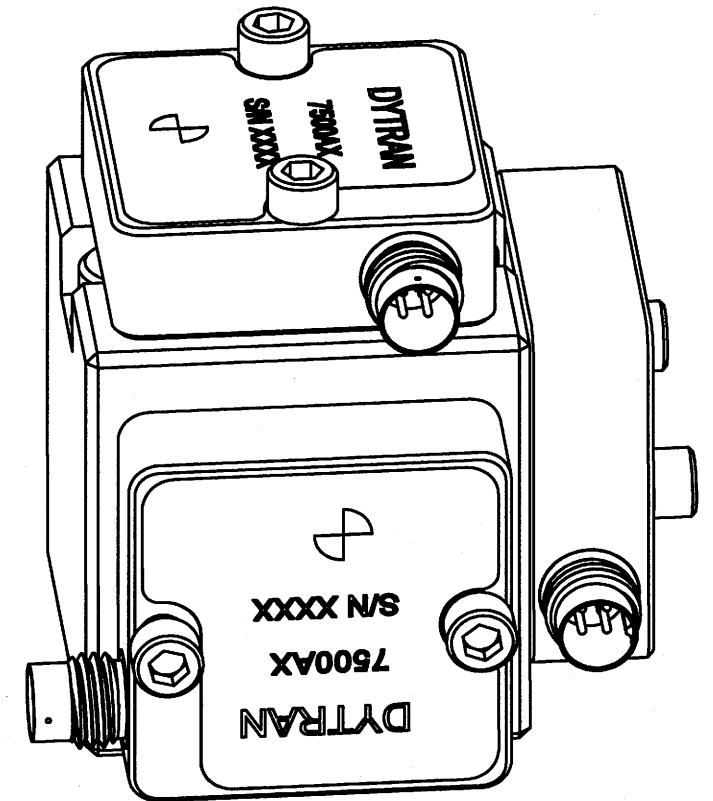
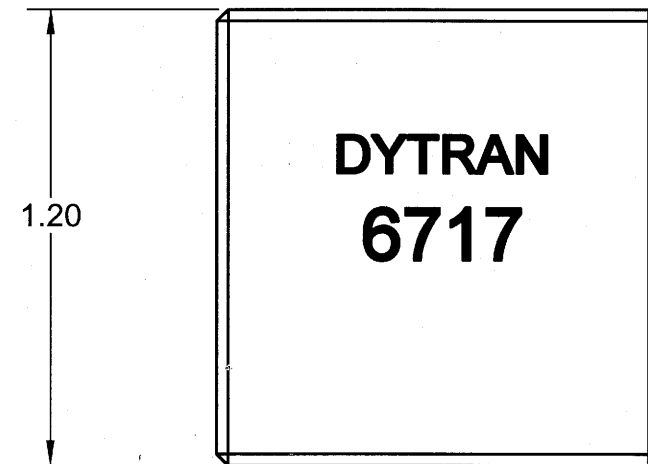
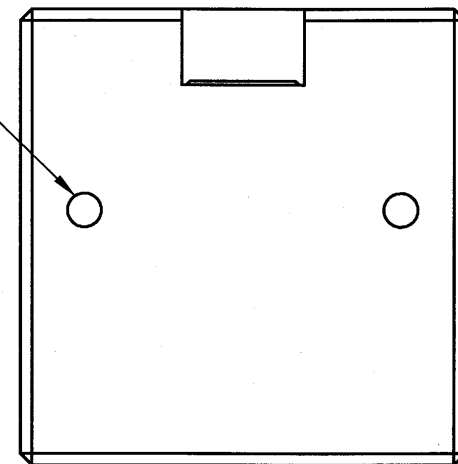
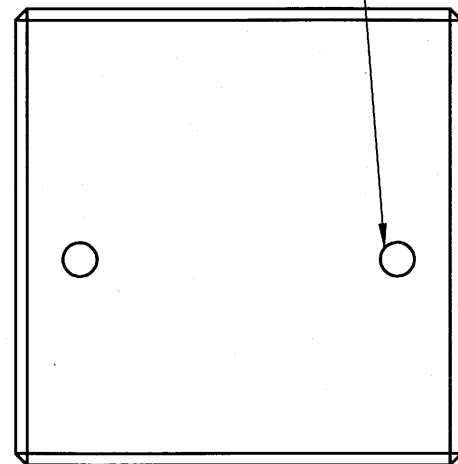
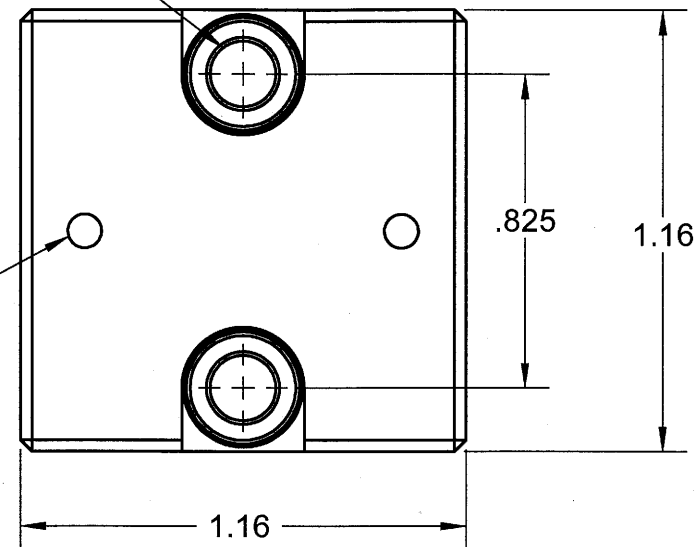

TYPICAL MOUNTING CONFIGURATION

PRELIMINARY

- NOTES:
 2 SUPPLIED:
 (3) 8-32 X 1.25 MOUNTING SCREWS
 (7) 4-40 X 0.5 MOUNTING SCREWS

1. MATERIAL: ANODIZED ALUMINUM

DRILL HOLE SIZE	TOLERANCE	UNLESS OTHERWISE SPECIFIED: INTERPRET DIM & TOL PER ASME Y14.5M - 1994. REMOVE BURRS. COUNTERSINK INTERNAL THDS 90° TO MAJOR DIA. CHAM EXT THDS 45° TO MINOR DIA. THD LENGTHS AND DEPTHS ARE FOR MIN FULL THDS. THDS PER MIL-S-7742. DIMENSIONS APPLY AFTER FINISHING
.0135 THRU .125	+0.004 / -.001	ALL MACHINED SURFACES. TOTAL RUNOUT WITHIN .005. BREAK SHARP EDGES .005 TO .010. MACHINED FILLET RADII .005 TO .015. WELDING SYMBOLS PER AWS A2.4. ABBREVIATIONS PER MIL-STD-12.
.1260 THRU .250	+0.005 / -.001	
.2510 THRU .500	+0.006 / -.001	
.5010 THRU .750	+0.008 / -.001	
.7510 THRU 1.000	+0.010 / -.001	
1.001 THRU 2.000	+0.012 / -.001	

THIRD ANGLE PROJECTION
USA

UNLESS OTHERWISE SPECIFIED:
DIMENSIONS ARE IN INCHES.
TOLERANCES ARE:

DECIMALS	ANGLES
.XX ± .010	± 1°
.XXX ± .005	

MATERIAL:

FINISH:

DO NOT SCALE DRAWING

CONTRACT NO.	
APPROVALS	DATE
ORIG	PML 4/18-07
CHK	
APP	
APP	

Chatsworth, CA	
TITLE:	
MOUNTING BLOCK	
SIZE	CAGE CODE
B	2W033
DWG NO	REV
127-6717	1
SCALE: 2:1	SHEET 1 of 1