

MODEL 3145A1G
ADHESIVE MOUNT

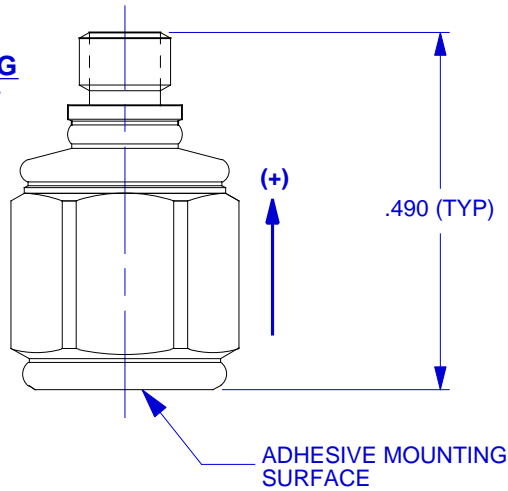

MODEL 3145A1
STUD MOUNT

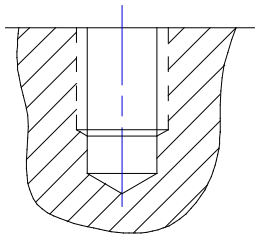
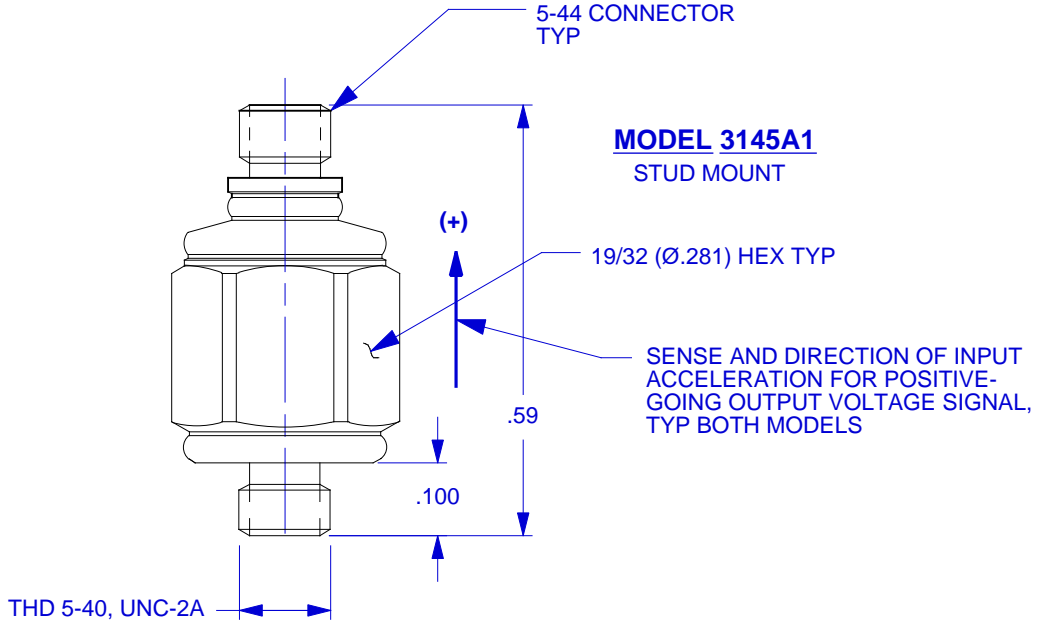

MOUNTING PORT PREPARATION:
DRILL #38 (Ø.1015) X.200 MIN DEPTH
TAP 5-40 X .140 MIN DEPTH THD

5. SUGGESTED ADHESIVE TYPE FOR MODEL 3145A1G-CYANOACRYLATE "INSTANT" BOND.
4. TO INSTALL MOD 3145A1, TORQUE IN PLACE WITH 10 OZ.-INCHES.
3. WEIGHT-MOD 3145A-1.6 GRAMS., MOD 3145AG-1.3 GRAMS
2. SEAL-HERMETIC, ALL WELDED.
1. MATERIAL: TITANIUM ALLOY.

ALL PART NUMBER LETTERSUFFIXES ARE TO BE INTERPRETED AS FOLLOWS:
I.E. - 107-0000-01 (X)

M - MACHINED ONLY (UNPLATED)	G - MATERIAL HAS BEEN GRAINED
P - PLATED/PAINTED	S - MATERIAL HAS BEEN SAWCUT
H - HEAT TREATED	E - ENVIRONMENTAL TEST

EXCEPT AS OTHERWISE NOTED

ALL DIMENSIONS IN INCHES
TOLERANCE: .XXX = ± .XX = ± .01

SURFACE FINISH EXCEPT AS NOTED ✓

BREAK EDGES TO DEBURR RADIUS OR CHAMFER

△ THESE DIAS ⊙ TO T.I.R.

FILLETS - MAX RAD.

		CHATSWORTH, CA.	
DATE 6/5/00	PART NO.		
DRAWN N.C.	CHECKED R.A.	MATERIAL	
APPROVED	NEXT ASSEMBLY	USED ON 3145A1 & 3145A1G	
TITLE		DWG NO.	
OUTLINE/INSTALLATION DRAWING MODELS 3145A1 & 3145A1G		127-3145A1	
		SHEET 1 OF 1	

SPECIFICATIONS
MODELS 3145A1 & 3145A1G ACCELEROMETERS

SPECIFICATION	VALUE	UNITS
PHYSICAL		
WEIGHT (Model 3145A1/3145A1G)	2.5/2.3	Grams
SIZE, HEX x HEIGHT (Height does not include mtg. stud)	.281 (9/32) x .49	Inches
MOUNTING PROVISION (Model 3145A1/3145A1G)	5-40 integral stud/adhesive mount	
CONNECTOR, TOP MOUNTED	5-44	Coaxial
MATERIAL, HOUSING AND CONNECTOR	300 Series	Stainless Steel
PERFORMANCE		
SENSITIVITY, $\pm 10\%$ [1]	10.0	mV/G
RANGE F.S. FOR ± 5 VOLTS OUTPUT	± 500	G's
FREQUENCY RANGE, $\pm 5\%$	0.5 to 10k	Hz
RESONANT FREQUENCY, NOM.	45	kHz
EQUIVALENT ELECTRICAL NOISE FLOOR	.035	G's RMS
LINEARITY [2]	$\pm 1\%$	% F.S.
TRANSVERSE SENSITIVITY, MAX.	5	%
STRAIN SENSITIVITY	.002	G's/ μ @ 250 μ
ENVIRONMENTAL		
MAXIMUM VIBRATION/SHOCK	600/3000	\pm G's/G's PEAK
TEMPERATURE RANGE	-60 to +300	$^{\circ}$ F
SEAL, HERMETIC	Glass-to-metal and TIG welded	
COEFFICIENT OF THERMAL SENSITIVITY	.04	%/ $^{\circ}$ F
ELECTRICAL		
SUPPLY CURRENT/COMPLIANCE VOLTAGE RANGE [3]	2 to 20/+18 to +30	mA/Volts
OUTPUT IMPEDANCE, TYP.	100	Ohms
BIAS VOLTAGE, +9 VOLTS NOM.	+8 to +10	VDC
DISCHARGE TIME CONSTANT, NOM.	0.5	Sec
OUTPUT SIGNAL POLARITY FOR ACCELERATION TOWARD TOP		Positive
CASE GROUNDING	Case is grounded to electrical power ground	

[1] Measured at 100 Hz, 1 G RMS per ISA RP 37.2.

[2] Measured using zero-based best straight line method, % of F.S. or any lesser range.

[3] Do not apply power to this device without current limiting, 20 mA MAX. To do so will destroy the integral IC amplifier.