

REV	ECN	DESCRIPTION	BY/DATE	CHK	APPR
A	5617	SEE ECN	RLA 11/20/08	JS	ANS
B	5645	SEE ECN	RLA 12/5/08	JS	ANS

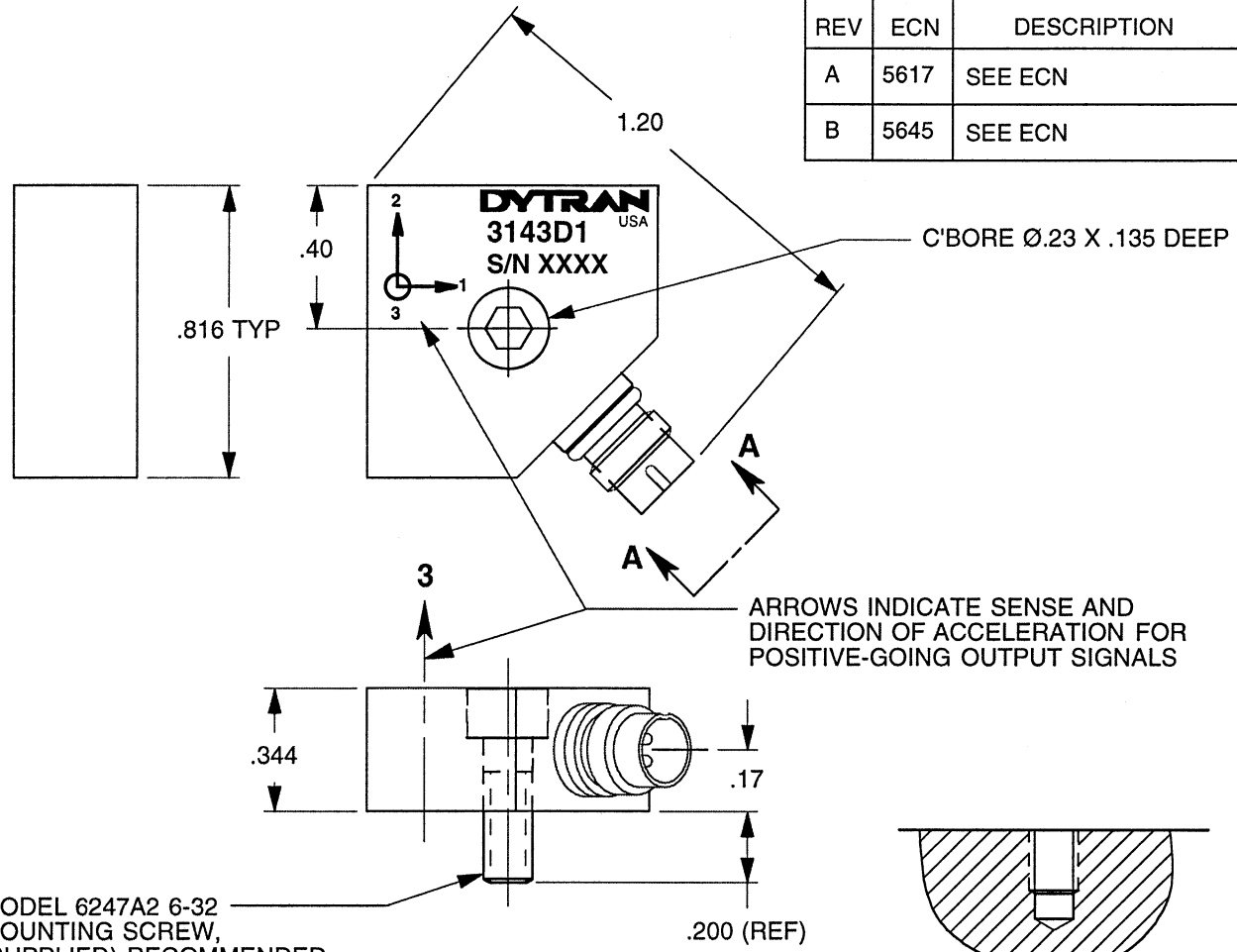

VIEW A-A LOOKING INTO CONNECTOR WITH CABLE DISCONNECTED

PINOUT
 PIN #1 GND RETURN, COMMON
 PIN #2 SIG/PWR AXIS 2 (Y)
 PIN #3 SIG/PWR AXIS 3 (Z)
 PIN #4 SIG/PWR AXIS 1 (X)

ARROWS INDICATE SENSE AND DIRECTION OF ACCELERATION FOR POSITIVE-GOING OUTPUT SIGNALS

MOUNTING PORT PREPARATION: DRILL #36 (Ø .1065) X .270 DEEP TAP 6-32 UNC-2B X .22 DEEP, MIN.

MODEL 6247A2 6-32 MOUNTING SCREW, (SUPPLIED) RECOMMENDED MOUNTING TORQUE: 10-15 LB-INCHES

5. RECOMMENDED CABLES: MODEL 6041CXX, FOR CONNECTION TO DYTRAN POWER UNITS 4113B AND 4103C. MODEL 6811AXX FOR CONNECTION TO MODEL 4114B FOUR-CHANNEL POWER UNIT.
4. WEIGHT: 14 GRAMS.
3. SIGNAL GROUND IS INSULATED FROM CASE GROUND.
2. ENVIRONMENTAL SEAL: HERMETIC.
1. HOUSING/CONNECTOR MATERIAL: TITANIUM.

EXCEPT AS OTHERWISE NOTED

ALL DIMENSIONS IN INCHES
 TOLERANCE: .XXX = ± .XX = ± .01

SURFACE FINISH EXCEPT AS NOTED ✓

BREAK EDGES TO DEBURR RADIUS OR CHAMFER

THESE DIAS ⊙ TO T.I.R.

FILLETS - MAX RAD.

DYTRAN INSTRUMENTS, INC.		MASTER ONLY IF IN RED		CHATSWORTH, CA.	
SCALE 2X	REV -	DATE SEE REV BLK	ECN -		
DATE 4/2/02	PART NO. MODEL 3143D1				
DRAWN N.C.	CHECKED R.A.	MAT'L			
APPROVED ANS 11/20/08	NEXT ASSEMBLY		USED ON 3143D1		
TITLE OUTLINE/INSTALLATION DRAWING, MODEL 3143D1, 100 mV/G				DWG NO. 127-3143D1	
				SHEET 1 OF 1	

SPECIFICATIONS

MODEL 3143D1 TRIAXIAL LIVM ACCELEROMETER

SPECIFICATION	VALUE	UNITS
PHYSICAL		
WEIGHT	14	gram
SIZE, L X W X H	.82 x .82 x .34	inch
MOUNTING PROVISION, THRU HOLE	6-32 MOUNTING SCREW	
CONNECTOR, RADIALLY MOUNTED	4-PIN	
MATERIAL, HOUSING & CONNECTOR	TITANIUM	
ELEMENT TYPE	SHEAR MODE	
PERFORMANCE		
SENSITIVITY, $\pm 5\%$ [1]	100	mV/g
RANGE F.S. FOR ± 5 VOLTS OUTPUT	± 50	g
FREQUENCY RANGE, $\pm 5\%$	0.5 to 3000	Hz
RESONANT FREQUENCY	>25	kHz
EQUIVALENT ELECTRICAL NOISE FLOOR	.0007	grms
LINEARITY [2]	$\pm 1\%$	% F.S.
TRANSVERSE SENSITIVITY, MAX.	5	%
STRAIN SENSITIVITY	.012	g's/ $\mu\epsilon$ @ 250 $\mu\epsilon$
ENVIRONMENTAL		
MAXIMUM VIBRATION	600	g pk
MAXIMUM SHOCK	1500	g pk
TEMPERATURE RANGE, OPERATING	-60 to +185	$^{\circ}$ F
TEMPERATURE RANGE, SURVIVAL	-100 TO +225	$^{\circ}$ F
SEAL, (WELDED, GLASS-TO-METAL CONNECTOR)	HERMETIC	
COEFFICIENT OF THERMAL SENSITIVITY	.03	%/ $^{\circ}$ F
ELECTRICAL		
SUPPLY CURRENT RANGE [3]	2 to 20	mA
COMPLIANCE VOLTAGE RANGE	+18 to +30	VDC
OUTPUT IMPEDANCE, TYP.	100	Ohms
BIAS VOLTAGE	+11 to +13	VDC
DISCHARGE TIME CONSTANT	0.8 to 1.5	Sec
OUTPUT SIGNAL POLARITY	positive	
FOR ACCELERATION TOWARD TOP		
ELECTRICAL ISOLATION, MIN.	10	GigOhms
CASE GROUND TO MOUNTING SURFACE		
RECOMMENDED CABLES	6811A (4-PIN CONNECTOR TO 3-BNC's FOR USE WITH MULTI CHANNEL POWER UNITS AS MODEL 4114B1)	

Accessories supplied: (1) Model 6247A2 mounting screw.

[1] Measured at 100 Hz, 1 G RMS per ISA RP 37.2.

[2] Measured using zero-based best straight line method, % of F.S. or any lesser range.

[3] Do not apply power to this device without current limiting, 20 mA MAX. To do so will destroy the integral IC amplifier.