

PROPRIETARY AND CONFIDENTIAL

THE INFORMATION CONTAINED IN THIS DRAWING IS THE SOLE PROPERTY OF DYTRAN INSTRUMENTS INC. ANY REPRODUCTION IN PART OR AS A WHOLE WITHOUT THE WRITTEN PERMISSION OF DYTRAN INSTRUMENTS INC IS PROHIBITED.

REVISIONS

REV.	ECN	DESCRIPTION	BY/DATE	CHK	APPR
1	4658	PRELIMINARY	RA 5/15/07		

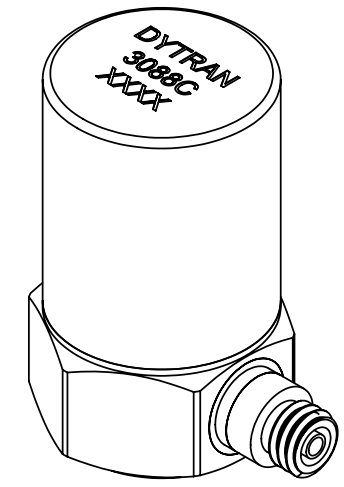
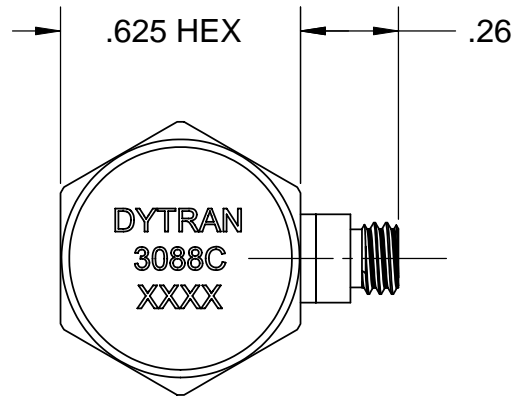

ISOMETRIC VIEW

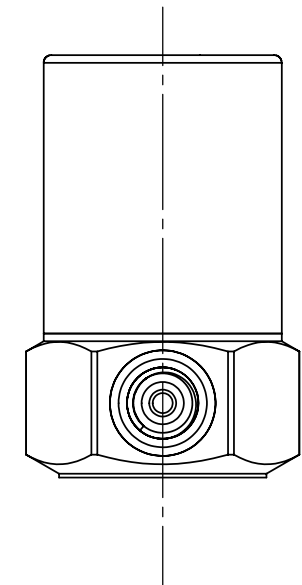
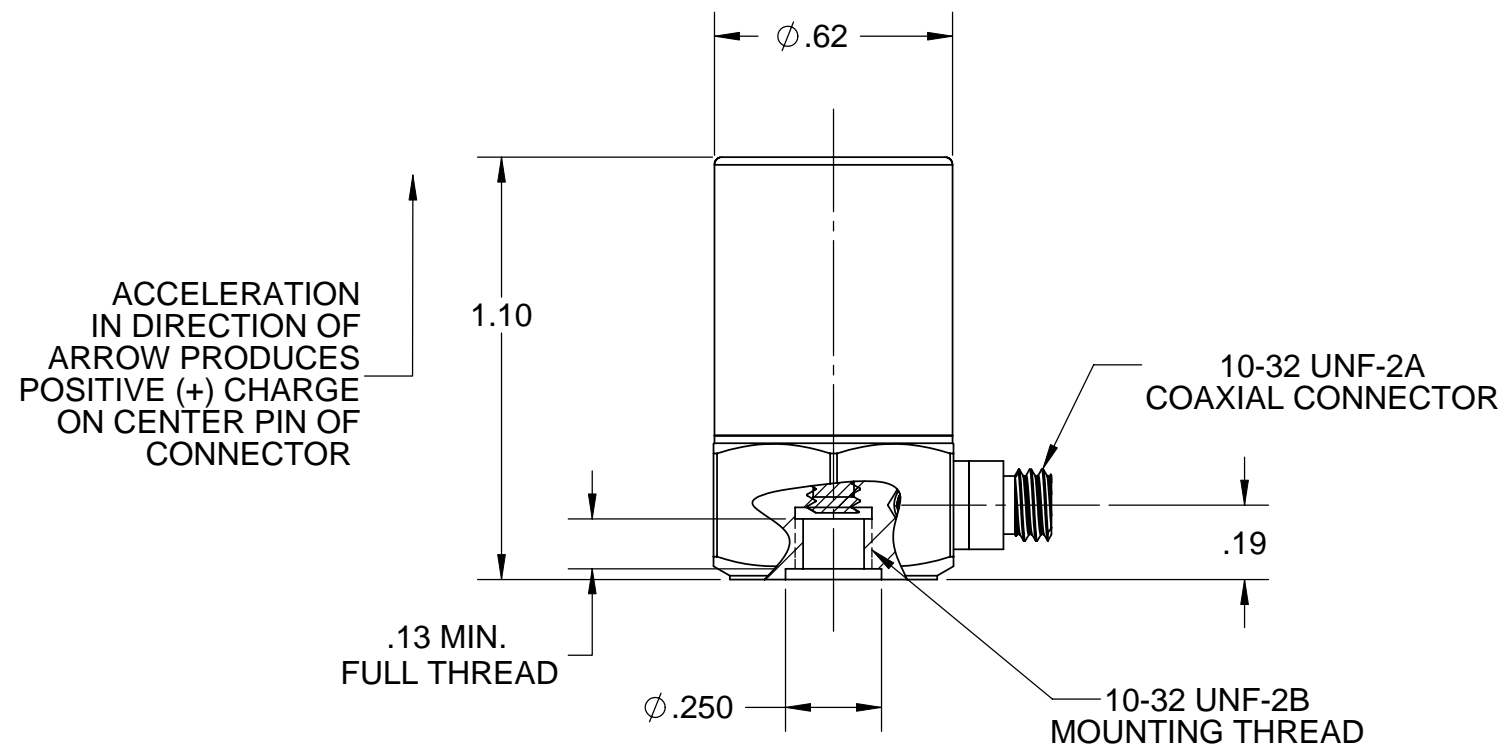

DRILL HOLE SIZE	TOLERANCE	UNLESS OTHERWISE SPECIFIED: INTERPRET DIM & TOL PER ASME Y14.5M - 1994. REMOVE BURRS. COUNTERSINK INTERNAL THDS 90° TO MAJOR DIA. CHAM EXT THDS 45° TO MINOR DIA. THD LENGTHS AND DEPTHS ARE FOR MIN FULL THDS. THDS PER MIL-S-7742. DIMENSIONS APPLY AFTER FINISHING.
.0135 THRU .125	+0.004 / -.001	ALL MACHINED SURFACES. $\sqrt{63}$ TOTAL RUNOUT WITHIN .005. BREAK SHARP EDGES .005 TO .010. MACHINED FILLET RADII .005 TO .015. WELDING SYMBOLS PER AWS A2.4. ABBREVIATIONS PER MIL-STD-12.
.1260 THRU .250	+0.005 / -.001	
.2510 THRU .500	+0.006 / -.001	
.5010 THRU .750	+0.008 / -.001	
.7510 THRU 1.000	+0.010 / -.001	
1.001 THRU 2.000	+0.012 / -.001	

THIRD ANGLE PROJECTION  
USA

UNLESS OTHERWISE SPECIFIED: DIMENSIONS ARE IN INCHES. TOLERANCES ARE: DECIMALS .XX ± .010 .XXX ± .005 ANGLES ± 1°		CONTRACT NO.	
MATERIAL:		APPROVALS	DATE
FINISH:		ORIG RA	3/19/2007
DO NOT SCALE DRAWING		CHK CES	
		APP PML	3/19/2007
		APP	

**DYTRAN**  
INSTRUMENTS, INC. Chatsworth, CA

TITLE: **OUTLINE DRAWING,  
MODEL 3088C**

SIZE <b>B</b>	CAGE CODE <b>2W033</b>	DWG NO <b>127-3088C</b>	REV <b>2</b>
------------------	---------------------------	----------------------------	-----------------

SCALE: 1:1      SOLIDWORKS      SHEET 1 of 1



**SPECIFICATIONS, MODEL 3088C CHARGE MODE ACCELEROMETER**

<b>SPECIFICATION</b>	<b>VALUE</b>	<b>UNITS</b>
<b>PHYSICAL</b>		
WEIGHT	42	grams
SIZE , HEX x HEIGHT	.625 x 1.07	inch
MOUNTING PROVISION	10-32 STUD	
CONNECTOR, SIDE MOUNTED	10-32 COAXIAL	
CASE /CONNECTOR MATERIAL	STAINLESS STEEL	
<b>PERFORMANCE</b>		
SENSITIVITY, +3.0 / -0.0 (NOM)	10	pC/g
FREQUENCY RESPONSE, +/- 5%	[1] to 5000	Hz
MOUNTED RESONANT FREQUENCY, NOM.	30	kHz
AMPLITUDE NON-LINEARITY (ZERO BASED BEST FIT ST.LINE METHOD)	2	% F.S., MAX.
TRANSVERSE SENSITIVITY, MAX.	3	%
STRAIN SENSITIVITY @ 250/με	.06	g/με
INSULATION RESISTANCE (300°F)	>5GΩ	
(500°F)	>200MΩ	
(600°F)	>2MΩ	
<b>ENVIRONMENTAL</b>		
MAXIMUM VIBRATION	±1000	G
MAXIMUM SHOCK	3000	g pk
TEMPERATURE RANGE	-65 TO +600	°F
THERMAL SENSITIVITY COEFFICIENT	<.018	%/°F
SEAL	WELDED/CERAMIC TO METAL HERMETIC	
<b>ELECTRICAL</b>		
CAPACITANCE, NOM.	370	pF
OUTPUT SIGNAL POLARITY FOR ACCELERATION TOWARD TOP	SEE INSTALLATION DRAWING	

**NOTES:**

[1] LOW FREQUENCY RESPONSE IS A FUNCTION OF THE CHARGE AMPLIFIER DISCHARGE TIME CONSTANT.

**SUPPLIED ACCESSORIES:**

(1) MOUNTING STUD, MODEL 6200 (10-32 TO 10-32).