

PROPRIETARY AND CONFIDENTIAL

THE INFORMATION CONTAINED IN THIS DRAWING IS THE SOLE PROPERTY OF DYTRAN INSTRUMENTS INC. ANY REPRODUCTION IN PART OR AS A WHOLE WITHOUT THE WRITTEN PERMISSION OF DYTRAN INSTRUMENTS INC. IS PROHIBITED

REVISIONS

REV.	ECN	DESCRIPTION	BY/DATE	CHK	APPR
A	6903	INITIAL RELEASE	RA 06/29/10	JS	ANS
B	7559	INITIAL RELEASE OF 3055B5	EP 06/13/11	<i>Dr</i>	<i>ANS</i>

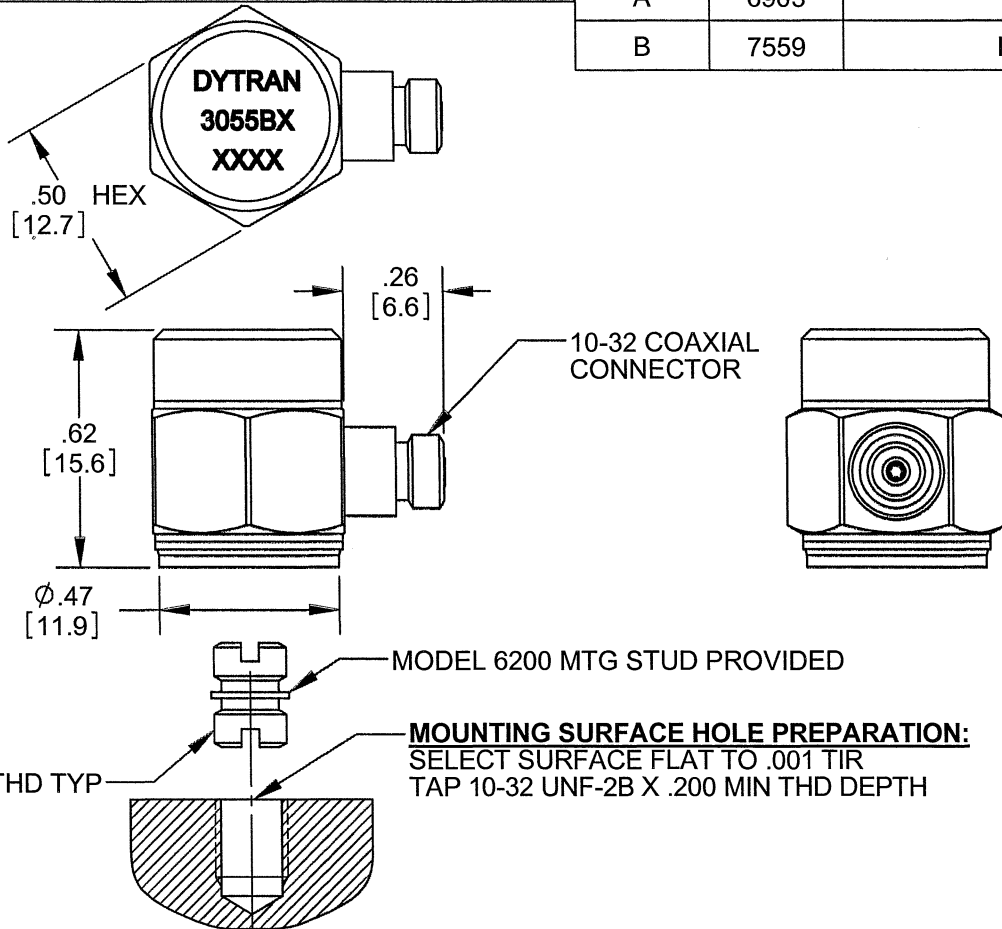

MODEL	SENSITIVITY	F.S. RANGE, +/-5V
3055B1	10 mV/g	±500 g's
3055B2	100 mV/g	±50 g's
3055B3	500 mV/g	±10 g's
3055B4	50 mV/g	±100 g's
3055B5	20 mV/g	±250 g's
3055B6	200 mV/g	±25 g's

1. CASE AND CONNECTOR MATERIAL: TITANIUM

NOTES: UNLESS OTHERWISE SPECIFIED

USED ON	NEXT ASSY	UNLESS OTHERWISE SPECIFIED: INTERPRET DIM & TOL PER ASME Y14.5M - 1994. REMOVE BURRS. COUNTERSINK INTERNAL THDS 90° TO MAJOR DIA. CHAM EXT THDS 45° TO MINOR DIA. THD LENGTHS AND DEPTHS ARE FOR MIN FULL THDS. THDS PER MIL-S-7742. DIMENSIONS APPLY AFTER FINISHING. ALL MACHINED SURFACES. TOTAL RUNOUT WITHIN .005. BREAK SHARP EDGES .005 TO .010. MACHINED FILLET RADII .005 TO .015. WELDING SYMBOLS PER AWS A2.4. ABBREVIATIONS PER MIL-STD-12.
APPLICATION		
THIRD ANGLE PROJECTION USA		UNLESS OTHERWISE SPECIFIED: DIMENSIONS ARE IN INCHES. DIMENSIONS IN BRACKETS [] ARE IN MILLIMETERS TOLERANCES ARE: INCHES METRIC ANGLES .XX ±.03 .X ±0.8 ±1° .XXX±.010 .XX ±0.25

MATERIAL	DO NOT SCALE DRAWING
FINISH	

CONTRACT NO.	
APPROVALS	
ORIG	PML 12/22/04
CHK	RA 08/30/06
APP	PML 08/31/06
APP	

DYTRAN INSTRUMENTS, INC. **MASTER** ONLY IF IN RED

TITLE: **OUTLINE/INSTALLATION DRAWING, MODEL SERIES 3055B**

SIZE	CAGE CODE	DWG. NO.	REV
A	2W033	127-3055B	B

SCALE: NONE SOLIDWORKS SHEET 1 OF 1

SPECIFICATIONS
MODEL SERIES 3055B LIVM ACCELEROMETERS

SPECIFICATION	VALUE						UNITS
PHYSICAL							
WEIGHT	10						Grams
SIZE, HEX x HEIGHT	.50 x 0.62						Inches
MOUNTING PROVISION	10-32 X .150 DEEP TAPPED HOLE						
CONNECTOR, RADIALLY MOUNTED	10-32						Coaxial
MATERIAL, BASE, CAP & CONNECTOR	TITANIUM						
SEISMIC ELEMENT TYPE	CERAMIC, PLANAR SHEAR						
PERFORMANCE							
	MODELS						
	3055B1	3055B2	3055B3	3055B4	3055B5	3055B6	
SENSITIVITY, ± 5% [1]	10	100	500	50	20	200	mV/g
RANGE F.S. FOR ± 5 VOLTS OUTPUT	± 500	±50	±10	±100	±250	±25	g's
FREQUENCY RANGE, ± 5% (all models)	1 to 10,000						Hz
RESONANT FREQUENCY, NOM. (all models)	35						kHz
EQUIVALENT ELECTRICAL NOISE (1Hz-10 kHz)	.001	.0002	.0002	.0003	.0002	.0002	grms
LINEARITY [2] (all models)	±2						% F.S.
TRANSVERSE SENSITIVITY, MAX. (all models)	5						%
ENVIRONMENTAL							
	3055B1	3055B2	3055B3	3055B4	3055B5	3055B6	
MAXIMUM VIBRATION/SHOCK	600/3000	400/2000	200/1000	500/2000	500/2000	300/2000	± gpk
TEMPERATURE RANGE	-60 to +250	-60 to +250	-60 to +225	-60 to +250	-60 to +250	-60 to +225	°F
SEAL, HERMETIC	Glass-to-metal/welded						
COEFFICIENT OF THERMAL SENSITIVITY	.06						%/°F
ELECTRICAL							
SUPPLY CURRENT [3]	2 to 20						mA
COMPLIANCE VOLTAGE RANGE	18 to +30						Volts
OUTPUT IMPEDANCE, TYP.	100						Ω
BIAS VOLTAGE	+11 to +13						VDC
DISCHARGE TIME CONSTANT	0.5 to 1.0						Sec
OUTPUT SIGNAL POLARITY FOR ACCELERATION TOWARD TOP	Positive						
ELECTRICAL ISOLATION, CASE GROUND TO MOUNTING SURFACE	10 min						MΩ

Accessories supplied: (1) Model 6200 mounting stud.

[1] Measured at 100 Hz, 1 grms per ISA RP 37.2.

[2] Measured using zero-based best straight line method, % of F.S. or any lesser range.

[3] Do not apply power to this device without current limiting, 20 mA MAX. To do so will destroy the integral IC amplifier.