

PROPRIETARY AND CONFIDENTIAL

THE INFORMATION CONTAINED IN THIS DRAWING IS THE SOLE PROPERTY OF DYTRAN INSTRUMENTS INC. ANY REPRODUCTION IN PART OR AS A WHOLE WITHOUT THE WRITTEN PERMISSION OF DYTRAN INSTRUMENTS INC. IS PROHIBITED

REVISIONS

REV	ECN	DESCRIPTION	BY/DATE	CHK	APPR
B	7056	INITIAL RELEASE	DV 08/31/10	<i>[Signature]</i>	<i>[Signature]</i>

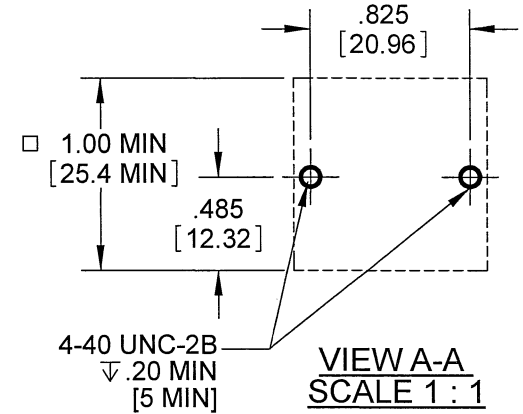
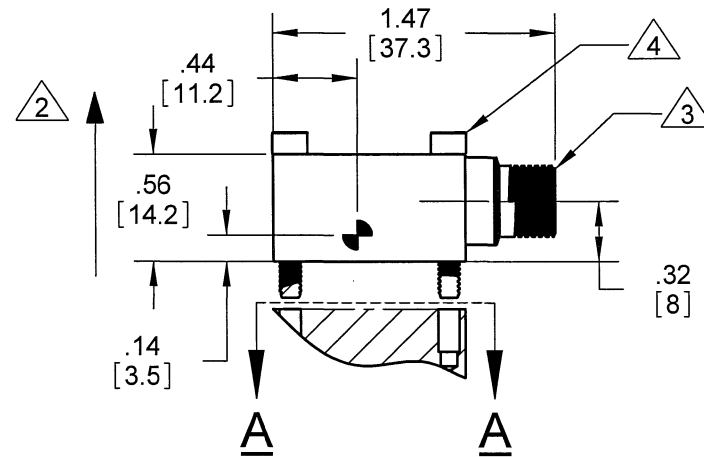
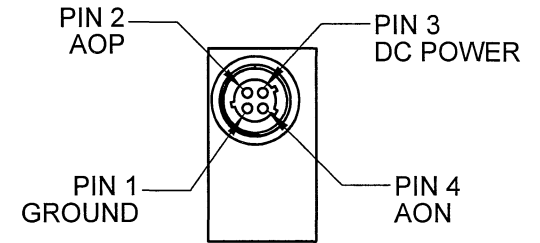
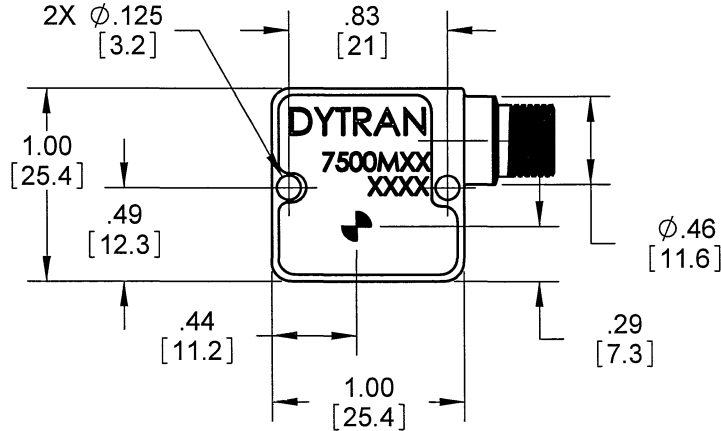
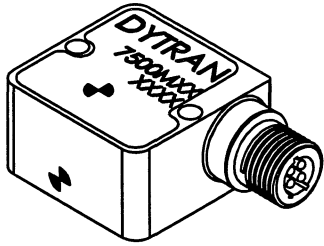

MOUNTING RECOMMENDATIONS

MODEL	SENSITIVITY
7500M10	40 mV/g
7500M11	5 mV/g

CUSTOMER APPROVAL: _____
DATE: _____

5. MOUNT TORQUE: 5-8 LB-IN

- 4** MOUNT WITH 6935 MODEL SCREW (2 SUPPLIED)
- 3** MATES WITH GLENAIR PLUG 800-06-M6-4SX
- 2** ARROW INDICATES ACCELERATION DIRECTION FOR POSITIVE OUTPUT

1. WEIGHT: 45 GRAMS MAX

NOTES: UNLESS OTHERWISE SPECIFIED

7500M10, M11	USED ON	NEXT ASSY
APPLICATION		
THIRD ANGLE PROJECTION USA		

UNLESS OTHERWISE SPECIFIED:
 INTERPRET DIM & TOL PER ASME Y14.5M - 1994.
 REMOVE BURRS.
 COUNTERSINK INTERNAL THDS 90° TO MAJOR DIA.
 CHAM EXT THDS 45° TO MINOR DIA.
 THD LENGTHS AND DEPTHS ARE FOR MIN FULL THDS.
 THDS PER MIL-S-7742.
 DIMENSIONS APPLY AFTER FINISHING.

ALL MACHINED SURFACES. ⁶³ TOTAL RUNOUT WITHIN .005.
 BREAK SHARP EDGES .005 TO .010.
 MACHINED FILLET RADII .005 TO .015.
 WELDING SYMBOLS PER AWS A2.4.
 ABBREVIATIONS PER MIL-STD-12.

UNLESS OTHERWISE SPECIFIED:
 DIMENSIONS ARE IN INCHES. DIMENSIONS IN BRACKETS [] ARE IN MILLIMETERS
 TOLERANCES ARE:
 INCHES METRIC ANGLES
 .XX ± .03 .X ± 0.8 ± 1°
 .XXX ± .010 .XX ± 0.25

MATERIAL _____
 FINISH _____

DO NOT SCALE DRAWING

CONTRACT NO.	
APPROVALS	
ORIG	DATE
CHK <i>[Signature]</i>	09/07/10
APP <i>[Signature]</i>	10/27/10
APP <i>[Signature]</i>	11/29/10

MASTER COPY ONLY IF IN RED
Chatsworth, CA

TITLE: **OUTLINE/INSTALLATION, ACCELEROMETER, 7500M10, M11**

SIZE A	CAGE CODE 2W033	DWG. NO. 127-7500M10	REV B
SCALE: NONE		SOLIDWORKS	SHEET 1 OF 1



- VARIABLE CAPACITANCE ACCELEROMETER
- DIFFERENTIAL MODE
- HERMETICALLY SEALED
- DC RESPONSE

PHYSICAL

Weight, Max
Connector
Mounting
Material

Type
Thru Holes

ENGLISH		SI	
1.6	oz	45	grams
4-PIN, 3/8-28UN-28		4-PIN, 3/8-28UN-28	
2 X Ø.13		2 X Ø.13	
304L		304L	

PERFORMANCE

Input Range
Frequency Response (-3dB), ± 50Hz [1]
Sensitivity Differential, ±10% [2]
Output Noise, Differential ,Typ
Non-Linearity, Max [4]
Transverse Sensitivity, Max
Scale Factor Calibration Error, Max
Zero Measured Output

±400	g	±4806	m/s ²
0-300	Hz	0-300	Hz
5	mV/g	0.5	mV/m/s ²
400	µ g rms/√ Hz	3,924	µ m/s ² /√ Hz
2	% Span	2	% Span
2	%	2	%
2	%	2	%
±50	mV	±50	mV

ENVIRONMENTAL

Maximum Mechanical Shock
Bias Temperature Shift ,Max [3]
Bias Calibration Error
Operating Temperature Range
Scale Factor Temperature Shift [3]
Seal

5000	gpk	49050	m/s ² peak
56	(ppm of span)/°F	100	(ppm of span)/°C
1.5	% of span	1.5	% of span
-67 to +257	°F	-55 to +125	°C
-83 to +83	ppm/°F	-150 to +150	ppm/°C
Hermetic		Hermetic	

ELECTRICAL

Output Common Mode Voltage, TYP
Output Impedence,Nom
Operating Voltage
Operating Current (AOP & AON open)
Power Supply Rejection Ratio

2.45	VDC	2.45	VDC
1	Ω	1	Ω
+9 to +32	VDC	+9 to +32	VDC
12 to 14	mA DC	12 to 14	mA DC
>65	dB	>65	dB

This family also includes:

Model	Input Range (g)	Frequency response (Hz)	Sensitivity Differential, ±10% (mV/g)	Max.Shock (gpk)	Noise Differential (µg rms/√Hz)
7500M10	± 50	0-300	40	5000	50

Refer to the performance specifications of the products in this family for detailed description.

Supplied Accessories:

- 1) Accredited calibration certificate (ISO 17025)
- 2) Two mounting screws model # 6935

Notes:

- [1] Low pass first order filter, corner frequency at 300Hz.
- [2] Single ended sensitivity is half of values shown.
- [3] Over the rated temperature range.
- [4] -90% to +90% of Full Scale.
- [5] In the interest of constant product improvement, we reserve the right to change specifications without notice.

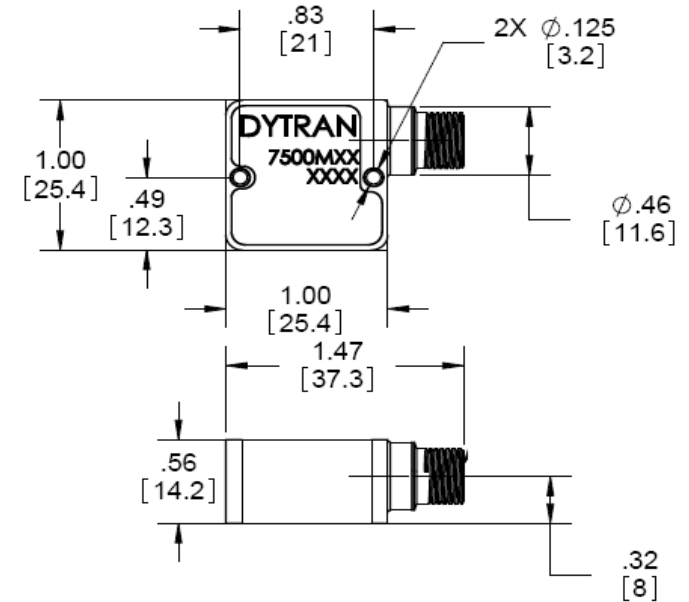

Units on the line drawing are in inches, dimensions in brackets [] are in millimeters. Refer to 127-7500M10 for more information.

