

REV	ECN	DESCRIPTION	BY/DATE	CHK	APPR
A	5436	INITIAL RELEASE	RLA 8/29/08	DV	DV

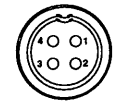
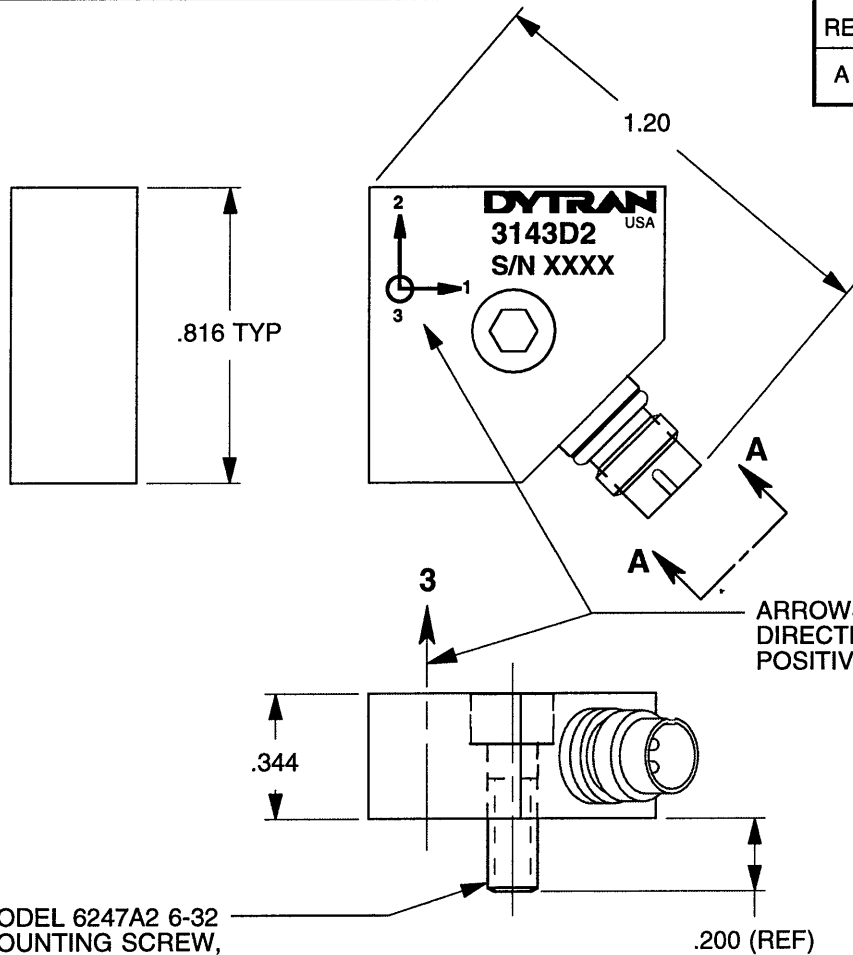

VIEW A-A LOOKING INTO CONNECTOR WITH CABLE DISCONNECTED

PINOUT
 PIN #1 GND RETURN, COMMON
 PIN #2 SIG/PWR AXIS 2 (Y)
 PIN #3 SIG/PWR AXIS 3 (Z)
 PIN #4 SIG/PWR AXIS 1 (X)

ARROWS INDICATE SENSE AND DIRECTION OF ACCELERATION FOR POSITIVE-GOING OUTPUT SIGNALS

MOUNTING PORT PREPARATION: DRILL #36 (Ø .1065) X .270 DEEP TAP 6-32 UNC-2B X .22 DEEP, MIN.

MODEL 6247A2 6-32 MOUNTING SCREW, (SUPPLIED) RECOMMENDED MOUNTING TORQUE: 10-15 LB-INCHES

5. RECOMMENDED CABLES: MODEL 6041CXX, FOR CONNECTION TO DYTRAN POWER UNITS 4113B AND 4103C. MODEL 6811AXX FOR CONNECTION TO MODEL 4114B FOUR-CHANNEL POWER UNIT.

4. WEIGHT: 14 GRAMS.

3. SIGNAL GROUND IS INSULATED FROM CASE GROUND.

2. ENVIRONMENTAL SEAL: HERMETIC.

1. HOUSING/CONNECTOR MATERIAL: TITANIUM.

EXCEPT AS OTHERWISE NOTED	
ALL DIMENSIONS IN INCHES	
TOLERANCE: .XXX ±	.xx ± .01
SURFACE FINISH EXCEPT AS NOTED	✓
BREAK EDGES TO DEBURR RADIUS OR CHAMFER	
△ THESE DIAS ⊙ TO	T.I.R.
FILLETS -	MAX RAD.

		<h1>MASTER ONLY IF IN RED</h1>		CHATSWORTH, CA.	
SCALE	2X	REV	DATE	SEE REV BLK	ECN
DATE	4/2/02	PART NO.	MODEL 3143D2		
DRAWN	N.C.	CHECKED	D.V.		MAT'L
APPROVED	D.V. 8/29/08		NEXT ASSEMBLY	USED ON	3143D2
OUTLINE/INSTALLATION DRAWING, MODEL 3143D2, 50 mV/G				DWG NO. 127-3143D2	
				SHEET 1 OF 1	

SPECIFICATIONS

MODEL 3143D2 TRIAXIAL LIVM ACCELEROMETER

SPECIFICATION	VALUE	UNITS
PHYSICAL		
WEIGHT	14	Grams
SIZE, L X W X H	.82 x .82 x .34	Inches
MOUNTING PROVISION, THRU HOLE	6-32 MOUNTING SCREW	
CONNECTOR, RADIALLY MOUNTED	4-PIN	
MATERIAL, HOUSING & CONNECTOR	TITANIUM	
ELEMENT TYPE	SHEAR MODE	
PERFORMANCE		
SENSITIVITY, $\pm 5\%$ [1]	50	mV/g
RANGE F.S. FOR ± 5 VOLTS OUTPUT	± 100	g's
FREQUENCY RANGE, $\pm 5\%$	0.5 to 3000	Hz
RESONANT FREQUENCY, NOM.	25	kHz
EQUIVALENT ELECTRICAL NOISE FLOOR	.0014	g's RMS
LINEARITY [2]	$\pm 1\%$	% F.S.
TRANSVERSE SENSITIVITY, MAX.	5	%
STRAIN SENSITIVITY	.012	g's/ $\mu\sigma$ @ 250 $\mu\sigma$
ENVIRONMENTAL		
MAXIMUM VIBRATION/SHOCK	600/1500	\pm g's/g's PEAK
TEMPERATURE RANGE, OPERATING	-60 to +185	$^{\circ}$ F
TEMPERATURE RANGE, SURVIVAL	-100 TO +225	$^{\circ}$ F
SEAL, (WELDED, GLASS-TO-METAL CONNECTOR)	HERMETIC	
COEFFICIENT OF THERMAL SENSITIVITY	.03	%/ $^{\circ}$ F
ELECTRICAL		
SUPPLY CURRENT RANGE [3]	2 to 20	mA
COMPLIANCE VOLTAGE RANGE	+18 to +30	VDC
OUTPUT IMPEDANCE, TYP.	100	Ohms
BIAS VOLTAGE, +12 VOLTS NOM.	+11 to +13	VDC
DISCHARGE TIME CONSTANT	0.8 to 1.5	Sec
OUTPUT SIGNAL POLARITY FOR ACCELERATION TOWARD TOP		Positive
ELECTRICAL ISOLATION, CASE GROUND TO MOUNTING SURFACE		10 Megohms, min.
RECOMMENDED CABLES	6041C (4-PIN CONNECTORS BOTH ENDS)	For use with 4113B or 4103C power units
	6811A (4-PIN CONNECTOR TO 3-BNC's)	For use with multi-channel power units such as Model 4114B

Accessories supplied: (1) Model 6247A2 mounting screw.

[1] Measured at 100 Hz, 1 G RMS per ISA RP 37.2.

[2] Measured using zero-based best straight line method, % of F.S. or any lesser range.

[3] Do not apply power to this device without current limiting, 20 mA MAX. To do so will destroy the integral IC amplifier.