

REV	ECN	DESCRIPTION	BY/DATE	CHK	APPR
A	-	INITIAL RELEASE	R.L.A. 1/3/03	N.C.	N.C.
B	4880	IS: AXIS 1 WAS: AXIS 2 IS: AXIS 2 WAS: AXIS 1	RLA 10/22/07	<i>RL</i>	<i>CS</i>

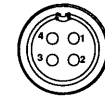
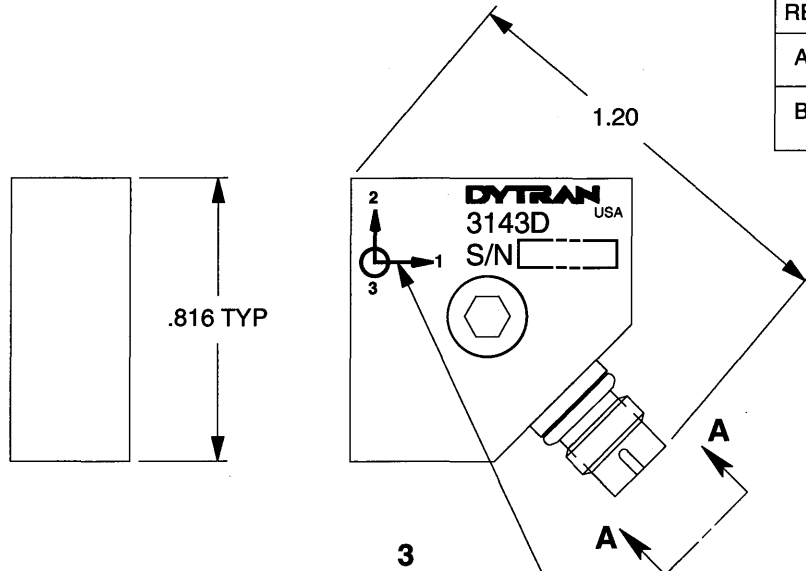

VIEW A-A LOOKING INTO CONNECTOR WITH CABLE DISCONNECTED

PINOUT
 PIN#1 GND RETURN, COMMON
 PIN#2 SIG/PWR AXIS 2 (Y)
 PIN#3 SIG/PWR AXIS 3 (Z)
 PIN#4 SIG/PWR AXIS 1 (X)

ARROWS INDICATE SENSE AND DIRECTION OF ACCELERATION FOR POSITIVE-GOING OUTPUT SIGNALS

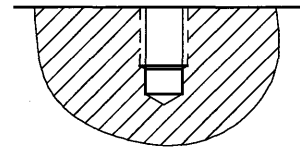
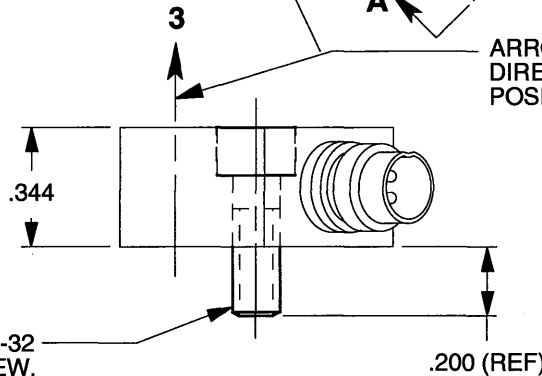

MOUNTING PORT PREPARATION: DRILL #36 (Ø .1065) X .270 DEEP TAP 6-32 UNC-2B X .22 DEEP, MIN.

- RECOMMENDED CABLES: MODEL 6041CXX, FOR CONNECTION TO DYTRAN POWER UNITS 4113B AND 4103C. MODEL 6811AXX FOR CONNECTION TO MODEL 4114B FOUR-CHANNEL POWER UNIT.
- WEIGHT: 14 GRAMS.
- SIGNAL GROUND IS INSULATED FROM CASE GROUND.
- ENVIRONMENTAL SEAL: HERMETIC.
- HOUSING/CONNECTOR MATERIAL: TITANIUM.

EXCEPT AS OTHERWISE NOTED

ALL DIMENSIONS IN INCHES
 TOLERANCE: .XXX ± .XX ± .01

SURFACE FINISH EXCEPT AS NOTED ✓

BREAK EDGES TO DEBURR RADIUS OR CHAMFER

THESE DIAS (⊙) TO T.I.R.

FILLET - MAX RAD.

DYTRAN INSTRUMENTS, INC.		MASTER ONLY IF IN RED		CHATSWORTH, CA.	
SCALE 2X	REV -	DATE SEE REV BLOCK	ECN -		
DATE 7/24/02	PART NO. MODEL 3143D				
DRAWN N.C.	CHECKED R.A.	MAT'L			
APPROVED N.C. 1/3/03	NEXT ASSEMBLY		USED ON	3143D	
TITLE OUTLINE/INSTALLATION DRAWING, MODEL 3143D, 10 mV/G			DWG NO.	127-3143D	
			SHEET 1	OF 1	

SPECIFICATIONS
MODEL 3143D TRIAXIAL LIVM ACCELEROMETER

SPECIFICATION	VALUE	UNITS
PHYSICAL		
WEIGHT	14	Grams
SIZE, L X W X H	.82 x .82 x .34	Inches
MOUNTING PROVISION, THRU HOLE	6-32 MOUNTING SCREW	
CONNECTOR, RADially MOUNTED	4-PIN	
MATERIAL, HOUSING & CONNECTOR	TITANIUM	
ELEMENT TYPE	SHEAR MODE, PIEZOCERAMIC	
PERFORMANCE		
SENSITIVITY, $\pm 5\%$ [1]	10.0	mV/g
RANGE F.S. FOR ± 5 VOLTS OUTPUT	± 500	g's
FREQUENCY RANGE, $\pm 5\%$	0.5 to 3000	Hz
RESONANT FREQUENCY	>25	kHz
EQUIVALENT ELECTRICAL NOISE FLOOR	.007	g's RMS
LINEARITY [2]	$\pm 1\%$	% F.S.
TRANSVERSE SENSITIVITY, MAX.	5	%
STRAIN SENSITIVITY	.012	g's/ $\mu\sigma$ @ 250 $\mu\sigma$
ENVIRONMENTAL		
MAXIMUM VIBRATION/SHOCK	600/1500	\pm g's/g's PEAK
TEMPERATURE RANGE, OPERATING	-60 to +185	$^{\circ}$ F
TEMPERATURE RANGE, SURVIVAL	-100 TO +225	$^{\circ}$ F
SEAL, (WELDED, GLASS-TO-METAL CONNECTOR)	HERMETIC	
COEFFICIENT OF THERMAL SENSITIVITY	.03	%/ $^{\circ}$ F
ELECTRICAL		
SUPPLY CURRENT RANGE [3]	2 to 20	mA
COMPLIANCE VOLTAGE RANGE	+18 to +30	VDC
OUTPUT IMPEDANCE, TYP.	100	Ohms
BIAS VOLTAGE	+11 to +13	VDC
DISCHARGE TIME CONSTANT	1 to 1.8	Sec
OUTPUT SIGNAL POLARITY FOR ACCELERATION TOWARD TOP	Positive	
ELECTRICAL ISOLATION, CASE GROUND TO MOUNTING SURFACE	10 min	Mohm
RECOMMENDED CABLES	6811A (4-PIN CONNECTOR TO 3-BNC's FOR USE WITH MULTI CHANNEL POWER UNIT, MODEL 4114B1)	

Accessories supplied: (1) Model 6247A2 mounting screw.

[1] Measured at 100 Hz, 1 G RMS per ISA RP 37.2.

[2] Measured using zero-based best straight line method, % of F.S. or any lesser range.

[3] Do not apply power to this device without current limiting, 20 mA MAX. To do so will destroy the integral IC amplifier.