

<b>PROPRIETARY AND CONFIDENTIAL</b>		REVISIONS					
THE INFORMATION CONTAINED IN THIS DRAWING IS THE SOLE PROPERTY OF DYTRAN INSTRUMENTS INC. ANY REPRODUCTION IN PART OR AS A WHOLE WITHOUT THE WRITTEN PERMISSION OF DYTRAN INSTRUMENTS INC. IS PROHIBITED		REV.	ECN	DESCRIPTION	BY/DATE	CHK	APPR
		B	6250	ADDED NOTE 5 & 6, REFORMATED	RA, 11/23/09	EP	DV
MODEL	SENSITIVITY	C	7540	ADDED MODEL 3023A4H, TEMPERATURE: RANGE - IS: 60° TO +325°F, WAS: 60° TO +320°F	JS 07/06/11	<i>[Signature]</i>	<i>[Signature]</i>
3023AH	10mV/G						
3023A3H	5mV/G						
3023A4H	1mV/G						

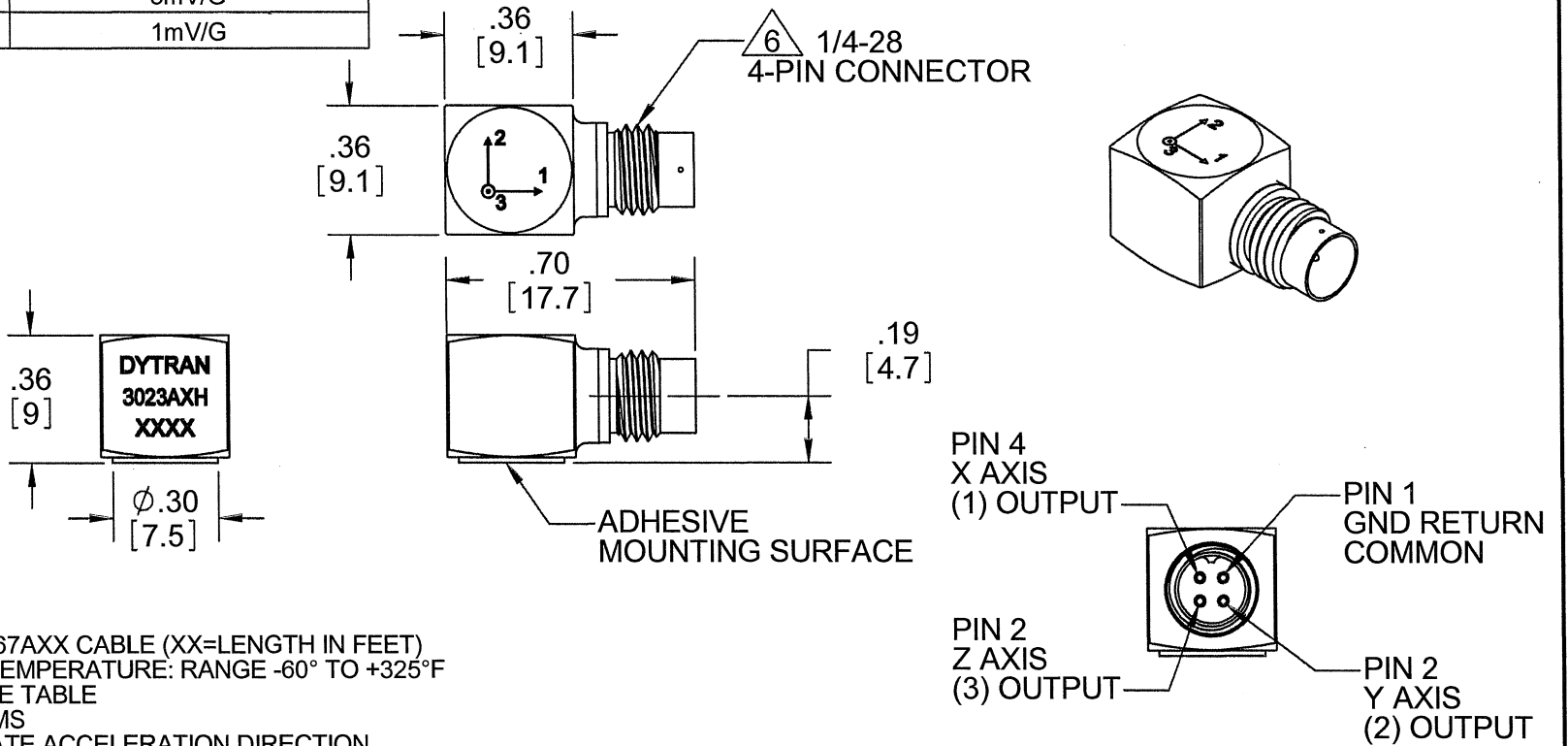

- 6. MATES WITH 6967AXX CABLE (XX=LENGTH IN FEET)
- 5. OPERATIONAL TEMPERATURE: RANGE -60° TO +325°F
- 4. SENSITIVITY: SEE TABLE
- 3. WEIGHT: 3 GRAMS
- 2. ARROWS INDICATE ACCELERATION DIRECTION FOR POSITIVE OUTPUT
- 1. MATERIAL: TITANIUM ALLOY

NOTES: UNLESS OTHERWISE SPECIFIED.

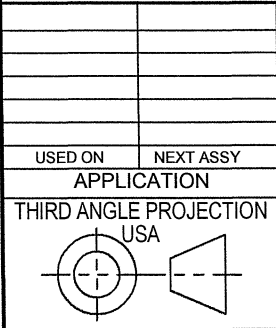

UNLESS OTHERWISE SPECIFIED:  
 INTERPRET DIM & TOL PER ASME Y14.5M - 1994.  
 REMOVE BURRS.  
 COUNTERSINK INTERNAL THDS 90° TO MAJOR DIA.  
 CHAM EXT THDS 45° TO MINOR DIA.  
 THD LENGTHS AND DEPTHS ARE FOR MIN FULL THDS.  
 THDS PER MIL-S-7742.  
 DIMENSIONS APPLY AFTER FINISHING.  
 ALL MACHINED SURFACES. TOTAL RUNOUT WITHIN .005.  
 BREAK SHARP EDGES .005 TO .010.  
 MACHINED FILLET RADII .005 TO .015.  
 WELDING SYMBOLS PER AWS A2.4.  
 ABBREVIATIONS PER MIL-STD-12.

UNLESS OTHERWISE SPECIFIED:  
 DIMENSIONS ARE IN INCHES. DIMENSIONS IN BRACKETS [ ] ARE IN MILLIMETERS  
 TOLERANCES ARE:  
 INCHES METRIC ANGLES  
 .XX ±.03 .X ±0.8 ±1°  
 .XXX±.010 .XX ±0.25

MATERIAL

FINISH

DO NOT SCALE DRAWING

CONTRACT NO.		
APPROVALS		DATE
ORIG	PML	06/12/05
CHK	CES	06/12/05
APP	DV	06/13/05
APP		

**DYTRAN INSTRUMENTS, INC.** Chatsworth, CA

**MASTER ONLY IF IN RED**

TITLE: **OUTLINE/INSTALLATION DRAWING, HIGH TEMPERATURE ACCELEROMETER**

SIZE	CAGE CODE	DWG. NO.	REV
<b>A</b>	<b>2W033</b>	<b>127-3023AH</b>	<b>C</b>

SCALE: 1:1      SOLIDWORKS      SHEET 1 OF 1



**SPECIFICATIONS, MODEL 3023AXH SERIES**

SPECIFICATIONS	VALUE		UNITS
<b>PHYSICAL</b>			
WEIGHT	3.0		GRAMS
SIZE (HEIGHT x WIDTH x DEPTH)	0.36 x .36 x .36		INCHES
MOUNTING	ADHESIVE MOUNT		
CONNECTOR	4-PIN [1]		
MATERIAL, HOUSING/CONNECTOR	TITANIUM ALLOY		
<b>PERFORMANCE</b>			
	<b>3023AH</b>	<b>3023A3H</b>	
SENSITIVITY, -10 +15% [2]	10.0	5.0	mV/G
RANGE, F.S. (each axis)	+/- 500	+/- 1000	G
FREQUENCY RESPONSE, -5 / +15%	1.5 to 10000		Hz
ELEMENT NATURAL FREQUENCY, NOM.	40		kHz
EQUIVALENT ELECTRICAL NOISE	.0095	.012	G, RMS
LINEARITY [3]	1		%F.S.
TRANSVERSE SENSITIVITY, MAX	6		%
SIGNAL POLARITY	POSITIVE FOR MOTION IN DIRECTION OF ARROWS ON HOUSING		
<b>ENVIRONMENTAL</b>			
MAXIMUM VIBRATION	+/- 600		G
MAXIMUM SHOCK	5000		G
TEMPERATURE RANGE	-60 to +325		°F
ENVIRONMENTAL SEAL	HERMETIC		
COEFFICIENT OF THERMAL SENSITIVITY	.03		%/°F
<b>ELECTRICAL</b>			
SUPPLY CURRENT RANGE, (each axis) [4]	2 to 20		mA
COMPLIANCE (SUPPLY) VOLTAGE RANGE (each axis)	+18 to +30		VDC
OUTPUT IMPEDANCE, TYP.	100		OHMS
OUTPUT BIAS VOLTAGE	+9 to +11 (+7 to +9 for <b>3023A3H</b> )		VDC
DISCHARGE TIME CONSTANT	0.3 -0.7		SEC
GROUND ISOLATION	CASE GROUNDED		

[1] Connector mates with Dytran cable assy. Model 6811Axx. (xx = length in feet)

[2] Reference sensitivity measured at 100 Hz, 1 G RMS per ISA RP 37.2

[3] Linearity is % of specified full scale (or any lesser full scale range), zero-based best fit straight line method.

[4] Power only with Dytran LIVM power unit or other Dytran-compatible constant current type power unit. If power is applied without current limiting protection, the internal amplifier will be immediately destroyed.